



DYNATRON CORPORATION

NEW PRODUCT SPEC SHEET

Sample Number: LG-264

- Recommended for Intel® Mini-ITX Desktop Board D945GCLF, D945GCLF2 & D945GCLF2D with Integrated Intel® Atom™ Processors
- Quietly Active Cooler for Mini-ITX Form Factor 1.2U & up (Min. 55mm)
- Replacement of Intel® 945GC Express Chipset Cooler refer to Component Space

Overall Specification:

- Dimension: 42 x 42 x 33.5mm
- Weight: < 85g
- Heat Sink Material: Aluminum Extrusion
- Thermal Interface: Honeywell PCM45D Pad
- 3-Pin Plastic Fan
- Support 82945 Series Chipset (ICH7) Power up to 22.2 Watts

Fan Specification:

- Dimension: 60 x 60 x 10mm
- Rated Speed: 2500 +0 / -200RPM
- Bearing: 2X Ball
- Rated Voltage: 12V
- Airflow: 12.4 CFM
- Acoustical Noise: 18.0 dBA
- Lead Wire Pin Out: Pin#1 - Black (-)
Pin#2 - Red (+)
Pin#3 – White (Tachometer / Signal output)

1 2 3 4 5 6 7

ITEM#	DESCRIPTION	CHECKER	DATE
1	Initial Release	LANG	03 / 12 / 09

A B C D E F G H

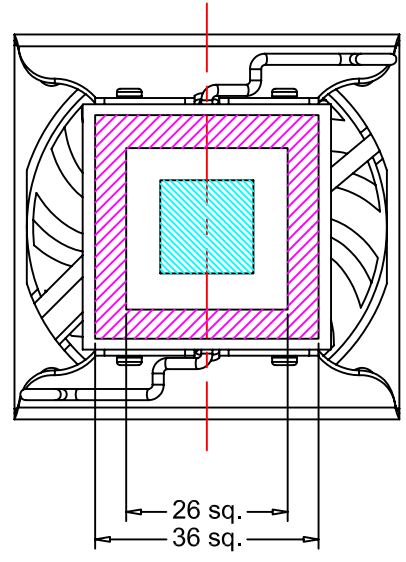
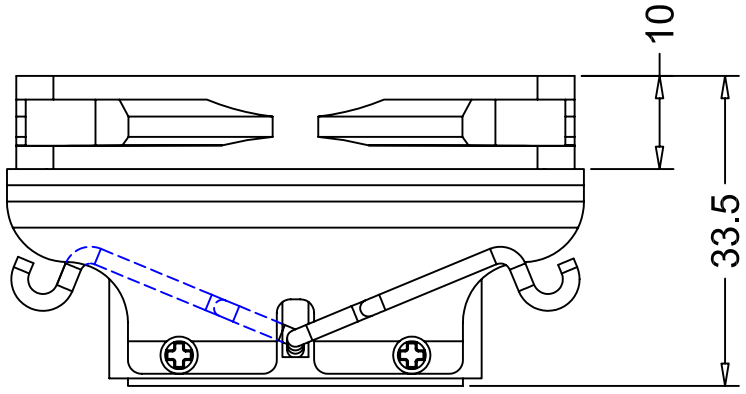
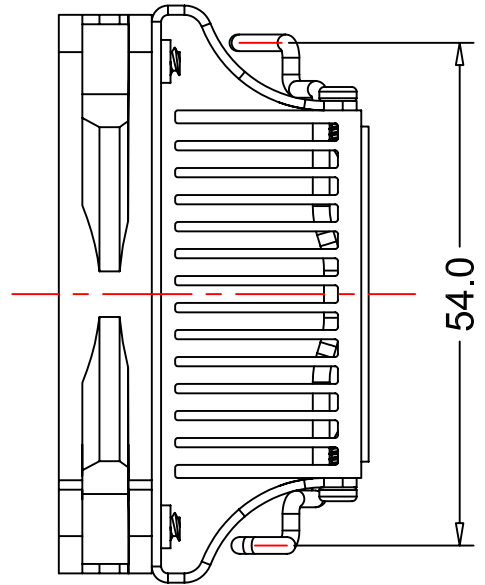
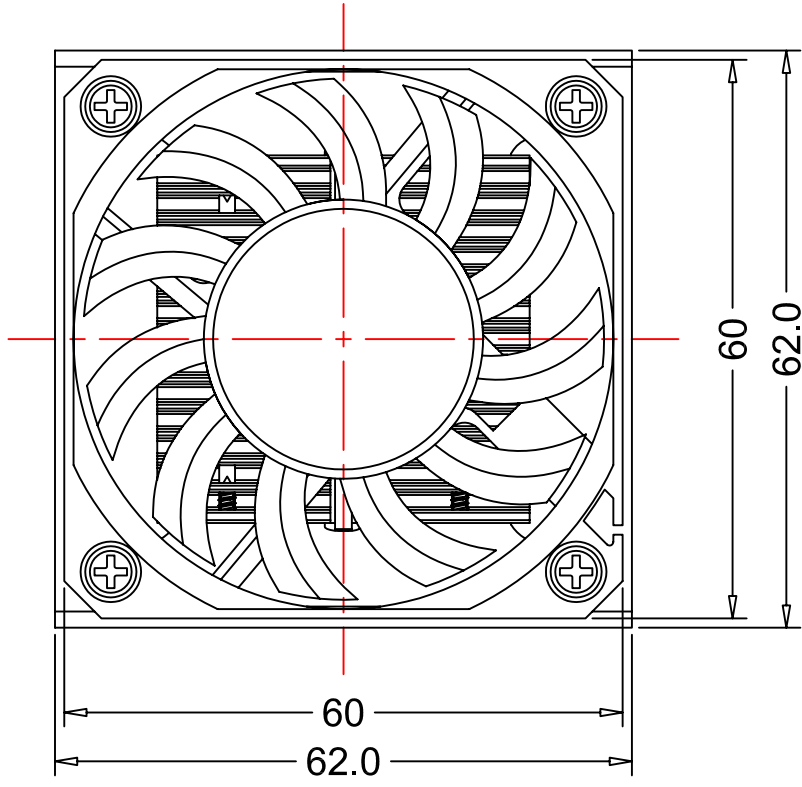

SCALE 2 : 3

5	SPONGE	PLASTIC	1
5	THERMAL PAD	PCM45F, 15X15mm	1
4	RETENTION CLIP	SWP	1
3	FAN COVER	ALUMINUM	1
2	FAN, 6010 3-PIN	PLASTIC	1
1	HEATSINK	ALUMINUM EXTRUSION	1
ITEM NO.	DESCRIPTION	MATERIAL	QTY.

	NAME	DATE
DRAWN BY	-	03 / 12 / 2009
CHECKED BY	LANG	03 / 12 / 2009
ENG. APPROVED		
MFG. APPROVED	-	-



DYNATRON CORPORATION

TITLE: **Chipset Cooler Sample LG-264 Overall Dimension Drawing**

CONFIDENTIAL DOCUMENT

THIS DRAWING CONTAINS INFORMATION PROPRIETARY TO DYNATRON CORPORATION AND DYNAEON INDUSTRIAL CO., LTD. ANY REPRODUCTION, DISCLOSURE, OR USE OF THIS DRAWING IS EXPRESSLY PROHIBITED EXCEPT AS DYNATRON CORPORATION AND DYNAEON INDUSTRIAL CO., LTD. MAY OTHERWISE AGREE TO IN WRITING.

VIEW		DWG. No:	
UNITS	MM		

REV. **00**

1 2 3 4 5 6 7