

# Installation Guide of NU-1270 Chassis

The structure of **NU-1270** chassis is designed with 2 separable housings –

1. Drive Cage – Housing for CD ROM/FDD/HDD (Illustration 1)
2. Main Frame – Housing for Motherboard and other peripherals (Illustration 2)

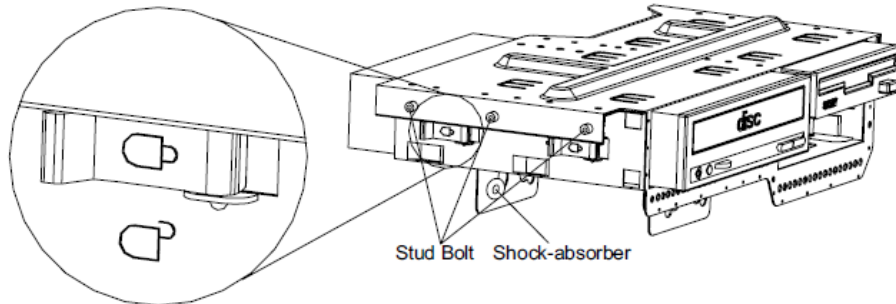

( Illustration 1 )

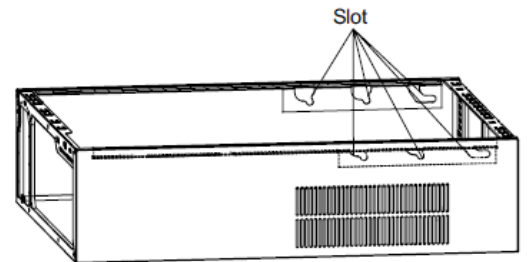

( Illustration 2 )

The 'Drive Cage' is integrated within the 'Main Frame' by –

6 units of small cylindrical 'Stud Bolts' (Illustration 1).

Each 'Stud Bolt', 3 on each side of the 'Drive Cage', seats and secures into -

6 corresponding 'Slots', 3 on each side, grooved on both sides of the 'Main Frame' (Illustration 2).

To take out the 'Drive Cage' from the 'Chassis Frame',

Lift up the rear side of the 'Drive Cage' to an angle of 45° and

Pull out the 'Drive Cage' from the 'Chassis Frame' (Illustration 3).

*Separated housings of 'Drive Cage' & 'Main Frame' enables opened space and flexible installation of Motherboard, CD ROM, FDD, HDD or other peripherals.*

*Drive Bays of 'Drive Cage' are provided with*

*'Flip-over and lock-down clips' for quick installation (Illustration 1),*

*Rubber cushion shock absorbers/metal buttons for vibrations and EMI control (Illustration 1).*

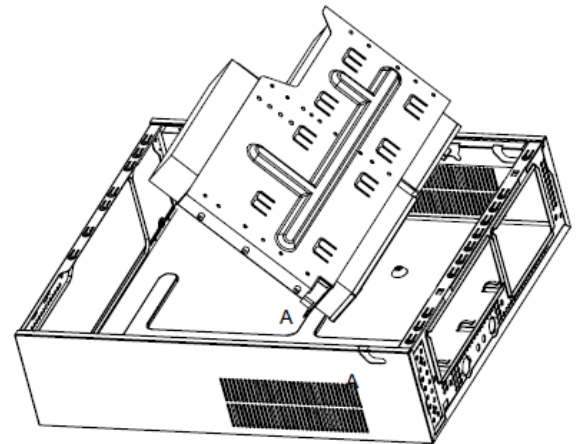

( Illustration 3 )

To seat back the 'Drive Cage' within the 'Main Frame' –

After all the peripherals are installed, hold the 'Drive Cage' at an angle of 45° , align and seat back the front 'Stud Bolt (A)' into 'Slot (A)' on the 'Chassis Frame' (Illustration 3).

Gently seats back the rear 'Stud Bolts' into its corresponding 'Slots' making sure that –

The Front I/O cables are free and not pressed by edges of the 'Drive Cage'.

All rights reserved

No part of this document may be reproduced, transmitted, transcribed, stored in a retrieval system or translated into any language or computer language, in any forms or by any means, electronic, mechanical, magnetic, optical, chemical, manual or otherwise